



**STAINLESS STEEL**

**150 LBS SCREWED FITTINGS**

**BSPP (ISO 228-1), BSPT (ISO 7-1), NPT THREAD**

DIMENSION CONFORM TO ASME B16.3 AND ANSI/MSS SP-114-2018 WHERE APPLICABLE

MATERIAL CONFORM TO ASTM A351 GR. CF8 & CF8M

PRESSURE-TEMPERATURE RATINGS 300 PSI (-29 TO 66°C)

MADE BY LOST WAX INVESTMENT CASTING

**UNION M.F. CONICAL SEAT**

Standard Pattern

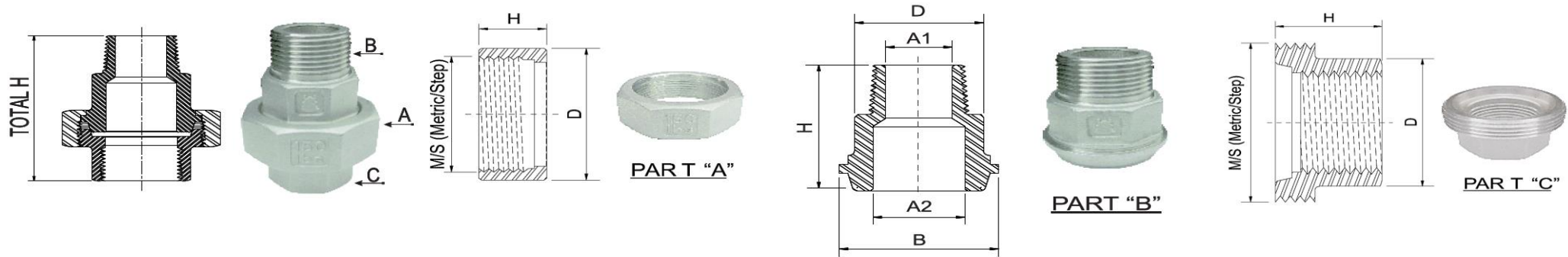

PART "A"

PART "B"

PART "C"

SIZE	Total H (mm)
¼"	50.0
⅜"	53.5
½"	57.5
¾"	64.5
1"	66.5
1¼"	79.0
1½"	87.0
2"	92.0
2½"	98.3
3"	117.3
4"	144.5

D (mm)	H (mm)	M/S (mm)
29.7	15.5	24
35.0	14.2	30
43.0	17.1	36
46.8	18.8	42
52.8	19.0	48
70.6	25.9	62
76.5	24.4	68
91.6	27.3	82
108.2	27.7	100
121.4	28.6	110
151.0	40.0	142

A1 (mm)	A2 (mm)	B (mm)	D (mm)	H (mm)
7.5	13.6	22.2	18.0	33.0
11.2	14.0	27.0	21.8	35.0
14.0	19.7	33.4	26.8	38.5
17.8	24.0	38.3	31.6	42.5
23.9	28.2	44.9	37.6	45.0
29.4	37.7	59.3	48.5	53.5
37.0	43.6	65.4	55.0	59.0
46.0	54.0	79.0	66.4	57.5
57.5	78.0	96.5	81.6	68.0
74.0	89.5	110.0	95.6	78.5
96.0	111.0	142.0	126.0	102.0

D (mm)	H (mm)	M/S (mm)
18.2	18.6	24
22.0	20.5	30
26.8	21.8	36
31.7	24.8	42
38.0	24.0	48
48.6	31.0	62
54.7	31.1	68
66.6	37.5	82
81.5	36.3	100
96.0	43.0	114
126.0	53.0	146

Weight Kg/Pc
0.09
0.13
0.21
0.28
0.37
0.83
0.95
1.41
1.94
2.47
4.95